

Variable displacement vane pumps (with hydraulic pressure compensator)

PSP-Type

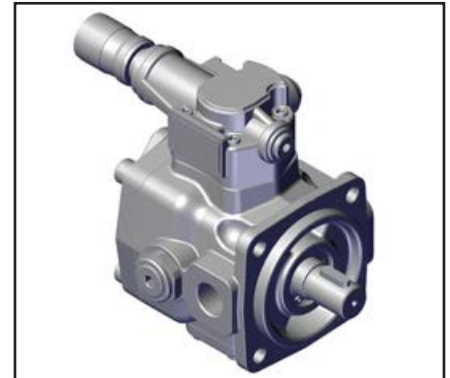

Key Features:

- Rotation:** Right (viewed from shaft end)
- Mounting flanges:** 4-hole flange (UNI ISO 3019/2)
- Connections:** GAS BSP (UNI ISO 228/1) and SAE
- Mechanical displacement limiter "Q" on request**
- All pumps are already set up as standard to be coupled to each other and with other types of pump**
- Wide choice of pressure and flow regulation controls**

Series/Name	Rated Displacement (cm ³ /r)	Maximum Flow Capacity at 1450 rpm (L/min)	Maximum Pressure (bar)
02-PSP-3-80	80	116	150
02-PSP-3-100	100	145	150

CONTENTS

GENERAL DESCRIPTION D-3

CHARACTERISTICS D-4

ORDERING CODE D-5

TECHNICAL DATA D-6

COMBINED PUMPS..... D-7

COMBINED PUMPS WITH SINGLE PRESSURE CONTROL DEVICE D-10

PRESSURE-FLOW CONTROL SOLUTIONS..... D-12

CHARACTERISTIC CURVES..... D-15

OVERALL DIMENSIONS D-16

ACCESSORIES D-17

INSTRUCTIONS FOR INSTALLATION AND USE D-19

WARNING

All Berarma pumps have been carefully checked during manufacture and subjected to stringent testing cycles before shipment. To achieve optimum performance, avoid problems and maintain the warranty, the installation instructions enclosed with each pump sold must be strictly observed.

NOTES

Before selection and/or use of any Berarma product, it is important that the purchaser carefully analyses all aspects of its application and reviews the information in the current Berarma Technical-Sales catalogues. Due to the many different operating conditions and applications for Berarma products, the purchaser, through their own analysis and testing, is solely responsible for making the final selection of the products and assuring that all performance and safety requirements are met.

Berarma S.r.l. accepts no responsibility for any editing mistakes in this catalogue.

Berarma S.r.l. reserves the right to modify the products and data contained in this catalogue at any time and without prior notice.

GENERAL DESCRIPTION

The PSP high pressure pumps (150 bar) are equipped with a HYDRAULIC pressure regulating device.

Pump components include: a body (1), a drive rotor (2) which houses the vanes (3), vanes that transport the fluid into the inlet and outlet chambers; a stator (4) (mobile circular ring) for varying eccentricity and consequently displacement; side distribution plates with AXIAL HYDROSTATIC COMPENSATION (5) which delimit the inlet and outlet chambers; a guide block balancing adjustment screw (6) (absolutely must not be tampered with by the user); a displacement adjustment piston (7), a maximum flow regulation screw (8) (available on request); a pressure control device (9); and a pressure regulator (10).

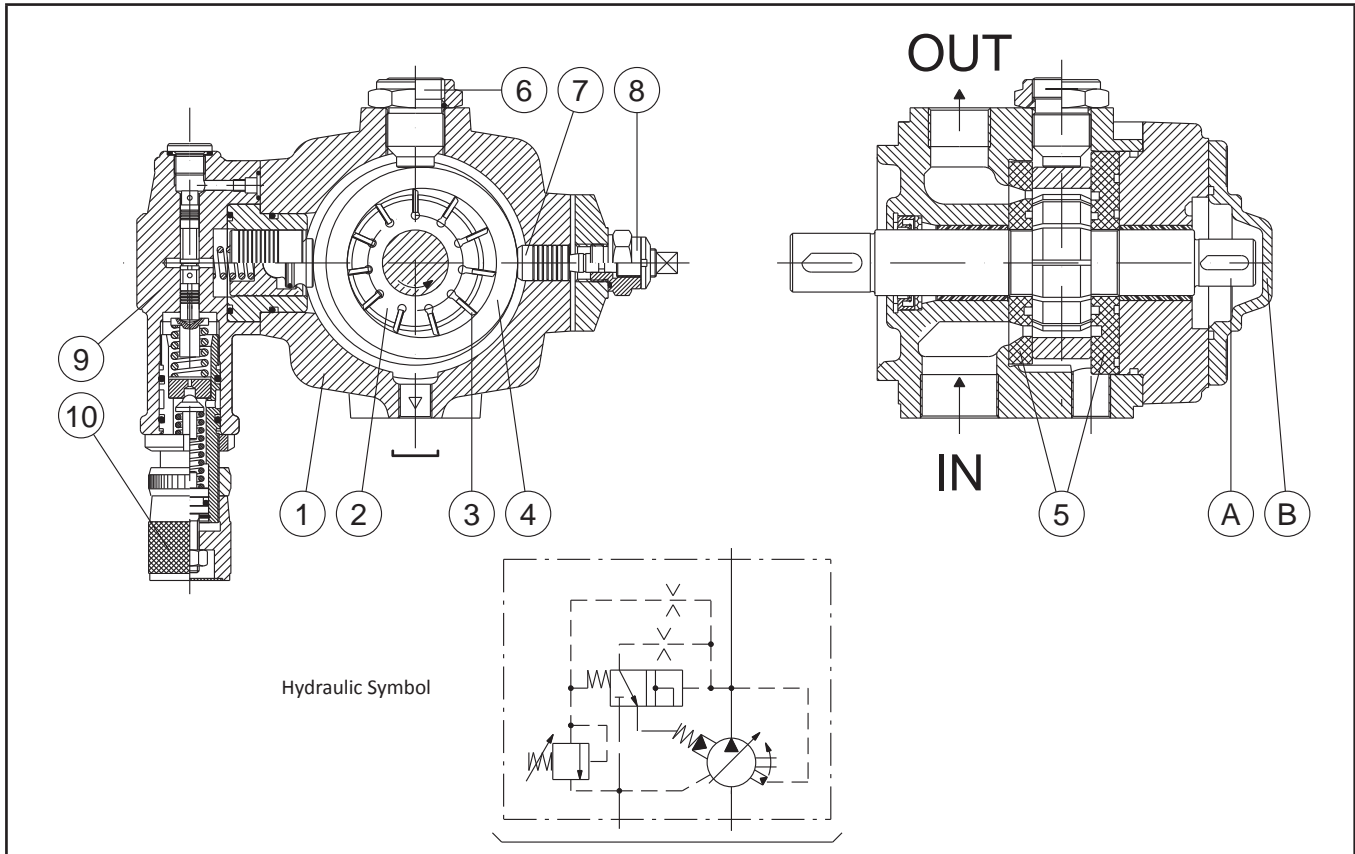

CHARACTERISTICS

- SILENT RUNNING from 63 to 72 dB(A)
- HIGH EFFICIENCY
- LONG WORKING LIFE
- The pumps can be supplied with various proportional devices for flow, pressure and power control
- ISO standard MOUNTING FLANGES
- GAS (BSP), SAE standard PORT CONNECTIONS
- MODULAR DESIGN: All Berarma pumps feature modular design for maximum flexibility and adaptability. The pumps comprise a body, common to each size, on which the various types of compensator devices (mechanical and hydraulic for pressure and flow control) can be mounted. The pump can therefore be converted from PVS to PSP and vice versa without any special modification, using the same standard pump body.

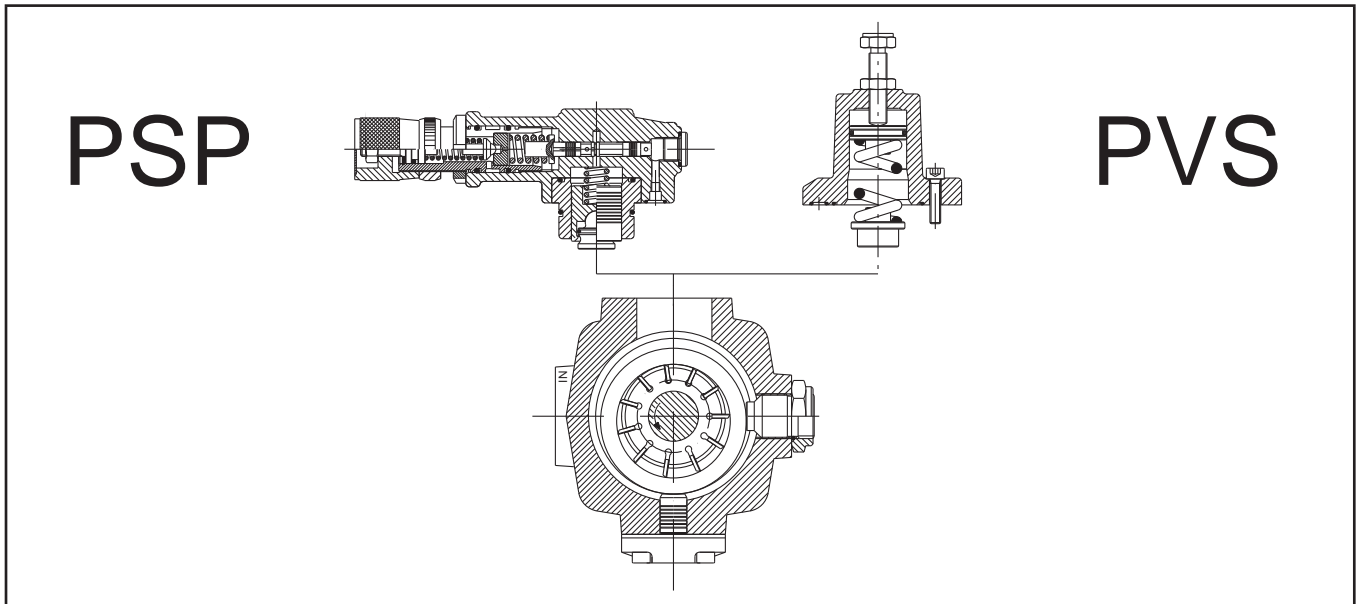

ORDERING CODE

ORDERING CODE

Series/ Name	Size Displacement	Flange	Pressure setting	Rotation	Seals	Controls Pressure	Options
02 PSP			H	R			

Code	Size	Displacement (cm ³ /r)																	
3 - 80	3	80																	
3 - 100	3	100																	
Code	Flange		Thread																
F	UNI ISO3019/2 - 4 holes		GAS UNI ISO 228/1; SAE																
Code	Pressure setting																		
H	30 - 150 bar																		
Code	Rotation Direction																		
R	Right (viewed from shaft end)																		
Code	Seals																		
M	NBR																		
E	FPM (viton)																		
Code	Size																		
/	Omit for single stage pressure compensator																		
PCS002	Pump with remote pressure control																		
PCS003	Pump with two-stage pressure control, one with fixed setting																		
PCS004	Pump with two-stage pressure control, both adjustable																		
PCS005	Pump with proportional pressure control																		
PCLS001	LOAD SENSING pump with single-stage pressure compensator																		
PCLS002	LOAD SENSING pump with remote pressure control																		
PCLS003	LOAD SENSING pump with two-stage pressure control, one with fixed setting																		
PCLS004	LOAD SENSING pump with two adjustable pressure stages																		
PCLS005	LOAD SENSING pump with proportional pressure control																		
Code	Options																		
KL	Key-Lock Compensator																		
Q	Displacement adjustment																		

Ordering code example:

- 02 PSP 3-80 F H R M Q PCS002
- 02 PSP 3-100 F H R M

TECHNICAL DATA

NOMINAL SIZE	Size 3
Geometric displacement according to UNI-ISO 3662 (cm³/r)	80 ÷ 100
Actual displacement (cm³/r)	86.2 ÷ 105.5
Maximum working pressure (bar)	150
Pressure setting range (bar)	H: 30 - 150
Permitted maximum drain port pressure (bar)	1
Inlet pressure (absolute - bar)	0.8 - 1.5
Speed range (r/min)	800 - 1800
Rotation direction (viewed from shaft end)	Right (clockwise) R
Loads on drive shaft	NO RADIAL OR AXIAL LOADS ALLOWED
Maximum torque on primary shaft (Nm)	740
Hydraulic fluid	HM hydraulic oil according to ISO 6743/4; HLP hydraulic oil according to DIN 51524/2; organic ester HFD-U according to ISO 6743/4 (Quintolubric 888); for other fluids contact Berarma Technical-Sales Service
Viscosity range (cSt, mm²/s)	22 - 68
Starting viscosity under full flow conditions (cSt, mm²/s)	400 max
Viscosity index according to ISO 2909	100 min
Inlet fluid temperature range (°C)	-10 - +50
Maximum acceptable fluid contamination level	20/18/15 according to ISO 4406/99, CLASS 9 according to NAS 1638
Recommended fluid contamination level for a longer pump working life	18/16/13 according to ISO 4406/99, CLASS 7 according to NAS 1638
Weight (kg)	45
For different operating conditions, please contact Berarma Technical Service	

COMBINED PUMPS

BERARMA pumps are already set up for coupling to one another or to other types of pump (see table of possible combinations). The standard rotor shaft is set up for coupling (see pump section view, detail "A", on page 3). After removal of cover "B", the pump can be fitted with the different units already set up for coupling.

With this solution BERARMA intends to avoid pumps with non-standard special applications, in order to simplify interchangeability and pump combination.

For solutions different to the ones described, please contact Berarma Technical Service.

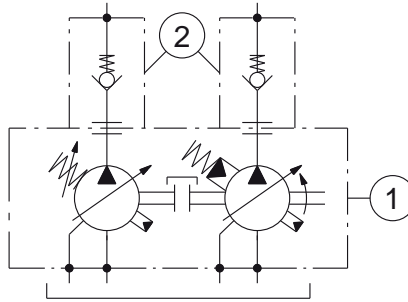

1) Combined Pumps

2) Non return valves - recommended installation (supplied on request)

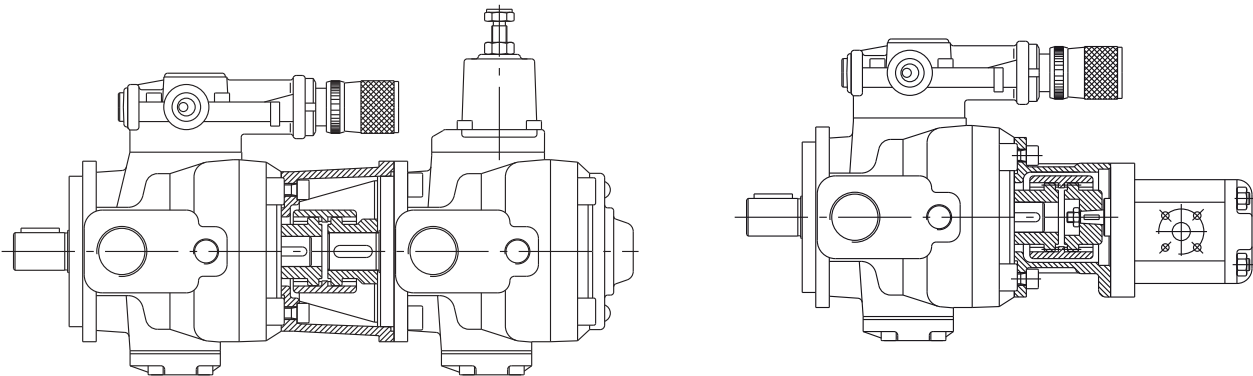

The ordering code should be specified according to the coupling sequence



Combined pumps should be mounted in decreasing order of absorbed power, paying attention to the maximum acceptable torques (see diagram below).

The ordering code for a combined pump should be specified according to coupling sequence (primary pump code + coupling unit code + secondary pump code).

- The sum of individual torques of all pumps in the complete pump combination must not exceed the maximum permissible torque value applicable to the primary pump shaft (T_{max} see page 6).
- Secondary pump torque (or sum of torques for more than one secondary pump) must not exceed the coupling unit maximum thru drive torque (T_a , see table below).

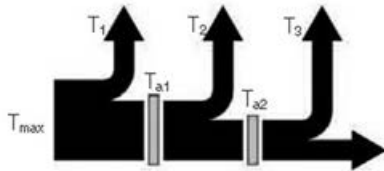

$$\begin{cases} T_1 + T_2 + T_3 < T_{max} \\ T_2 + T_3 < T_{a1} \\ T_3 < T_{a2} \end{cases}$$

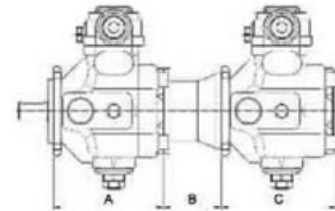

PRIMARY PUMP		SECONDARY PUMP		COUPLING UNIT		
Pump type	A	Pump type	C	Code	B	Maximum thru drive torque T_a
02 PSP 3 (80-100) F	198	GEAR PUMP SIZE 1P	(*)	3000022000	90	110 Nm
		GEAR PUMP SIZE 1	(*)	3000022100	90	
		GEAR PUMP SIZE 2	(*)	3000022200	90	
		GEAR PUMP SIZE 3	(*)	3000022300	90	
		01 PLP 05 16 F	107	3000020400	85	
		01 PLP 05 16 FGR2	107	3000022200	90	
		01 PHP 05 16 F	145	3000020400	85	
		01 PHP 05 16 FGR2	145	3000022200	90	
		01 PLP 1 (20-25-32) F	166	3000020100	87	
		01 PHP 1 (20-25-32) F	166	3000020100	87	
		01 PLP 2 (40-50-63) F	202	3000020200	102	
		01 PHP 2 (40-50-63) F	202	3000020200	102	
		SAE "A"	(*)	3100000200	100.5	
		SAE "B"	(*)	3100000300	126.5	
		02 PVS 3 (80-100) F	245	3000020300	117	180 Nm
02 PSP 3 (80-100) F	245	3000020300	117			

(*) For the secondary pump SAE A flange dimensions please see page 9.

In order to find out the secondary SAE flange pump axial dimension please see the manufacturer's catalogue.

(*) For the secondary gear pump flange dimensions please see page 9.

In order to find out the secondary gear pump axial dimension please see the manufacturer's catalogue.

For other coupling unit types, please contact Berarma Technical-Sales Service.

SAE FLANGE DIMENSIONS FOR BERARMA COUPLING KIT

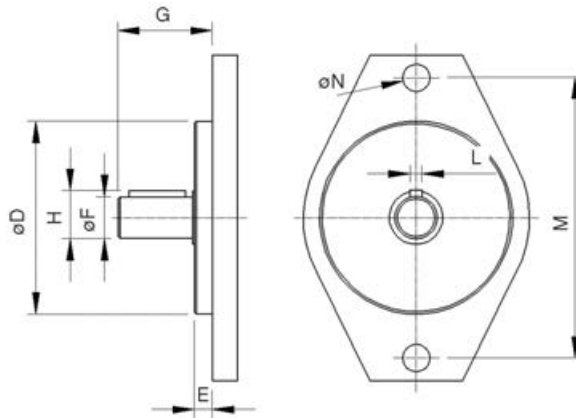

Secondary pump	Secondary pump with SAE flange should conform to the dimensions below								
	$\varnothing D$	E	$\varnothing F$	G		H	L	M	$\varnothing N$
				min	max				
SAE "A"	$\varnothing 82.5$	7	$\varnothing 19.05$	32	59	21.1	4.8	106.4	11.1
SAE "B"	$\varnothing 101.6$	9.5	$\varnothing 22.2$	41	71	25.1	6.375	146	14.3
						25.5	4.8		

GEAR PUMP FLANGE DIMENSIONS FOR BERARMA COUPLING KIT

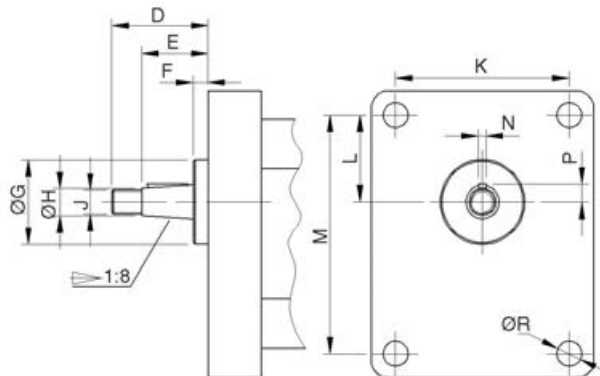

Secondary pump	Secondary gear pumps should conform to the dimensions below											
	D	E	F	$\varnothing G$	$\varnothing H$	J	K	L	M	N	P	$\varnothing R$
gear pump 1P	29	20	4	25.4	8	M7	52.4	26.2	71.9	2.4	5.3	7.5
gear pump 1	35	23.5	5.5	30	12	M10x1	56	24.5	73	3	7.9	6.5
gear pump 2	40	28	5	36.5	14.7	M12x1.5	71.5	32.5	96	4 (*)	9.7	8.5
gear pump 3	47	33	5	50.8	19	M14x1.5	98.5	43	128	4	12.2	11

For further information, please consult the leaflet "Installation and start-up instructions for PSPC-type variable displacement vane combined pumps with single pressure control device".

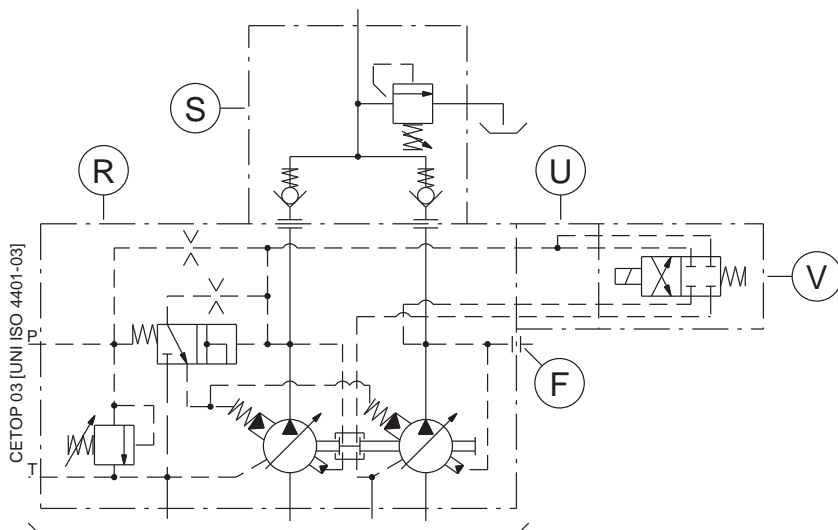

Geometric displacement (cm ³ /r)	126	143	160	180	200
Actual displacement (cm ³ /r)	138	155.2	172.4	191.7	211

R -	Combined pumps with single pressure control device.
S -	Outlet manifold with check valves and maximum pressure relief valve. Supplied on request. Installation recommended.
F -	1/4" GAS (BSP) port connection for pressure gauge.
U -	Manifold block, with CETOP 03 [UNI ISO 4401-03] mounting surface, for solenoid operated directional control valve to vent air.
V -	Solenoid operated directional control valve to vent air. Supplied on request (specify coil type). Must be installed in case of starting under zero flow setting conditions.

ORDERING CODE

	1	2	3	4	5	6	7	8	9	10
	SERIES	NAME	SIZE	DISPLACEMENT	FLANGE	PRESS. SETTING	ROTATION	SEALS	PRESS. CONTROLS	OPTIONS
E.G.	02	PSPC	3	200	F	H	R	M	PCS...	KL

- | | | | |
|----------|---|-----------|--|
| 1 | PUMP SERIES = 02 | 6 | PRESSURE SETTING = H 30-120 bar |
| 2 | PUMP NAME = PSPC | 7 | ROTATION = R (Right-hand [clockwise] rotation viewed from shaft end) |
| 3 | PUMP SIZE = 3 | 8 | SEALS = M (NBR) |
| 4 | DISPLACEMENT CM ³ /R = 126, 143, 160, 180, 200 | 9 | PRESSURE-FLOW CONTROL SOLUTIONS page 13 |
| 5 | FLANGE AND PORT CONNECTIONS=
F (Flange: UNI ISO 3019/2
Inlet-Outlet: flange SAE J518
Drain port: GAS BSP UNI ISO 228/1 thread) | 10 | OPTIONS = KL (Key lock compensator) |

PCS002
PCS003
PCS004
PCS005

PRESSURE-FLOW CONTROL SOLUTIONS

PSP pumps can be supplied with a wide range of electro-hydraulic devices for pressure and flow control. In addition to its various pressure regulating systems, Berarma has developed a LOAD-SENSING device for its pumps (see diagrams with characteristic curves). This solution make Berarma pumps suitable to be used in energy saving systems.

LOAD - SENSING

The LOAD-SENSING flow regulating system is relatively simple; the signal for the compensator is picked up from the pump pressure line after a restriction and before an actuator.

The regulating system (restriction) may comprise: throttle, manual or proportional type, or quick/slow units. As the extent of the restriction (at a fixed pressure drop $\Delta p=20$ bar [*]) changes, pump displacement is automatically varied by the system regardless of pressure variations in the circuit. The LOAD-SENSING system enables the notable limitation of power dissipation and is particularly suitable for applications with considerable torque (or force) and speed variations.

[*] Note: For different operating conditions, please contact Berarma Technical Service.

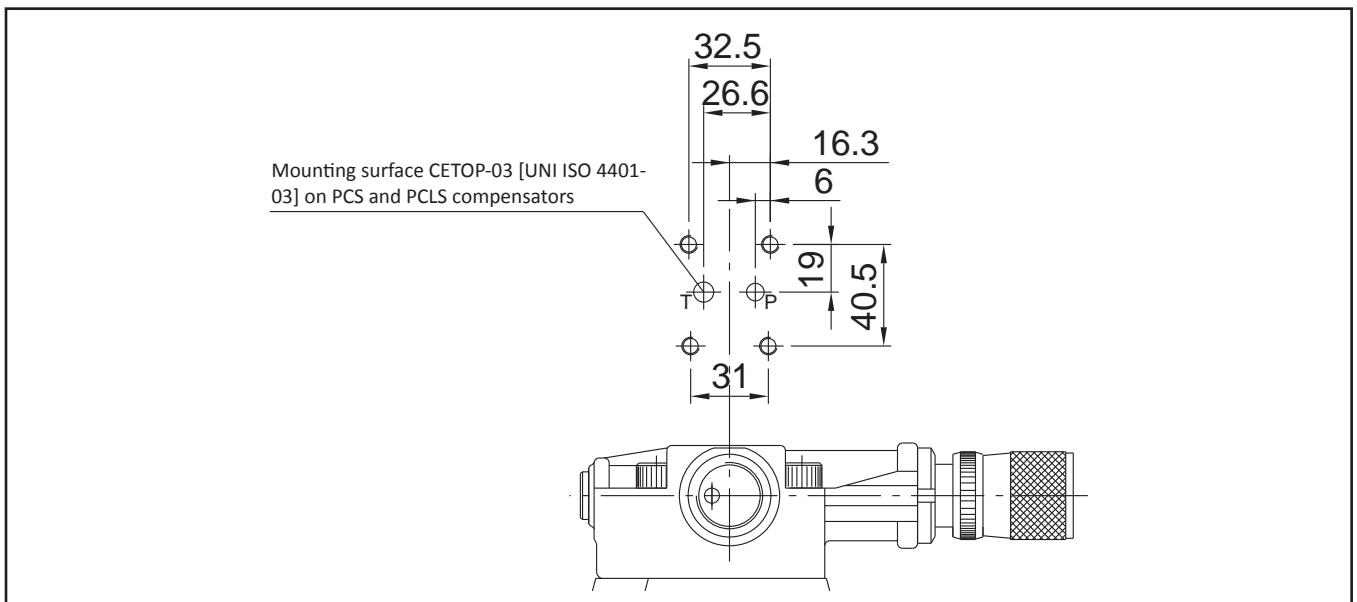

Diagrams and characteristic curves for pressure regulation

1 Pump with standard pressure compensator

2 Pump with pressure compensator with CETOP 03 [UNI ISO 4401-03]

P	CS002
P	CS003
P	CS004

3 Pump with pressure compensator for proportional regulation with CETOP 03 [UNI ISO 4401-03]

P	CS005
---	-------

Pump with two-stage pressure control, one of which is fixed (at the minimum pressure setting of the pump)

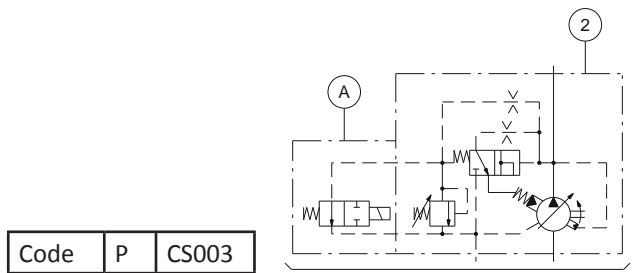

Code	P	CS003
------	---	-------

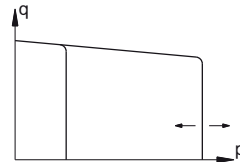

A - Solenoid valve supplied only on request (please specify coil type)

Standard pump

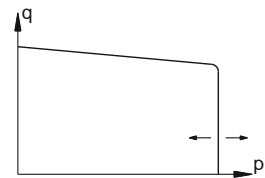
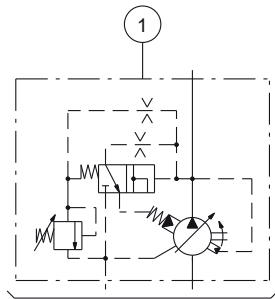

Pump with two-stage pressure control, both adjustable

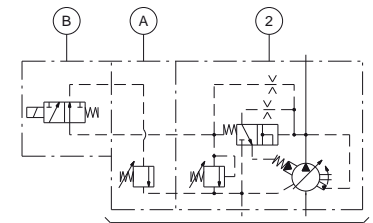

Code	P	CS004
------	---	-------

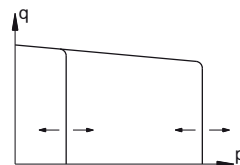

A - Berarma pressure relief valve supplied factory-assembled and tested
B - Solenoid valve supplied only on request (please specify coil type)

Pump with remote pressure control

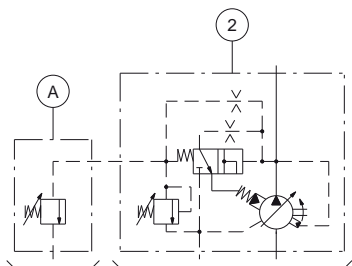

Code	P	CS002
------	---	-------

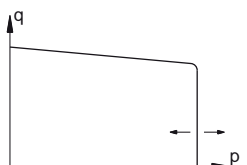

A - Maximum pressure relief valve (0-5 l/min) not supplied
Note

- The length of the pilot pipe between the compensator and the valve must not exceed 5 m
- Remote control port 1/4" Gas (BSP)

Pump with proportional pressure control

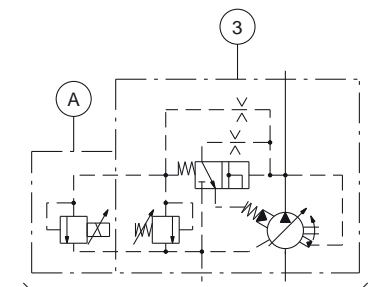

Code	P	CS005
------	---	-------

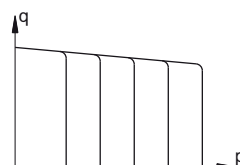

A - Pressure control proportional valve supplied only on request

Diagrams and characteristic curves for combined LOAD SENSING and pressure regulation

- 1 LOAD SENSING pump with standard pressure regulation

P	CLS001
---	--------
- 2 LOAD SENSING pump with CETOP 03 mounting surface [UNI ISO 4401-03]

P	CLS002-3-4-5
---	--------------
- 3 Manual-electrical-proportional flow regulator not supplied

Note

- The length of the individual pipe between the flow regulator and the LOAD SENSING device must not exceed 5 m
- Load Sensing signal connection 1/4" Gas

LOAD SENSING pump with two-stage pressure control, one of which is fixed (at the minimum pressure setting of the pump)

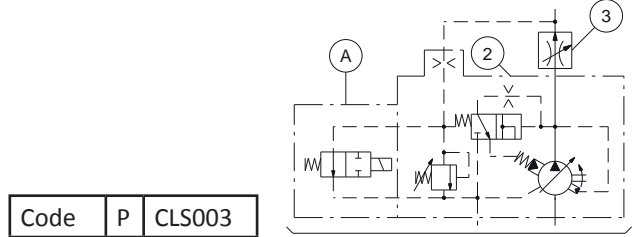

Code	P	CLS003
------	---	--------

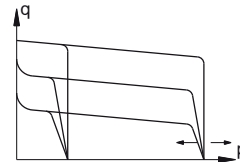

A - Solenoid valve supplied only on request (please specify coil type)

LOAD SENSING pump with standard pressure regulation

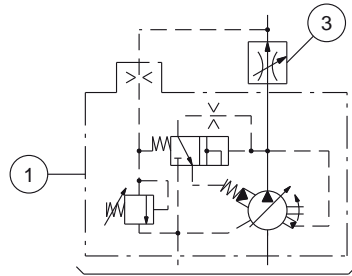

Code	P	CLS001
------	---	--------

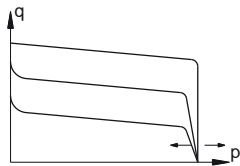

LOAD SENSING pump with two adjustable pressure stages

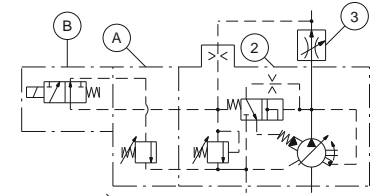

Code	P	CLS004
------	---	--------

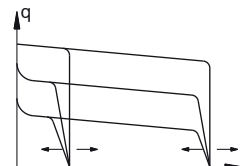

A - Berarma pressure relief valve supplied factory-assembled and tested
B - Solenoid valve supplied only on request (please specify coil type)

LOAD SENSING pump with remote pressure control

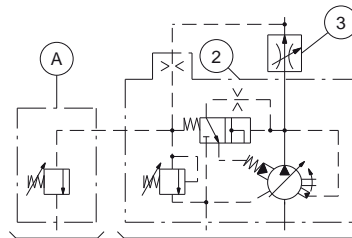

Code	P	CLS002
------	---	--------

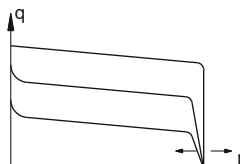

A - Maximum pressure relief valve (0-5 l/min) not supplied
Note

- The length of the pilot pipe between the compensator and the valve must not exceed 5 m
- Remote control port 1/4" Gas (BSP)

LOAD SENSING pump with proportional pressure control

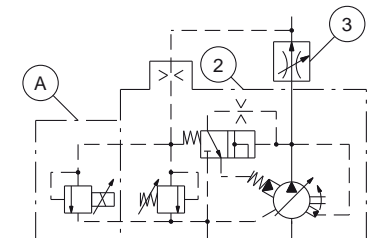

Code	P	CLS005
------	---	--------

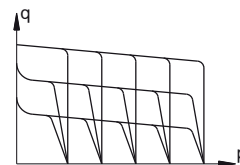

A - Pressure control proportional valve supplied only on request

CHARACTERISTIC CURVES

Indicative values related to 1450 r/min., HM hydraulic oil according to ISO 6743/4, ISO VG 32 according to ISO 3448, temperature 50°C

02 PSP 3 80-100

volumetric efficiency -zero flow setting curve

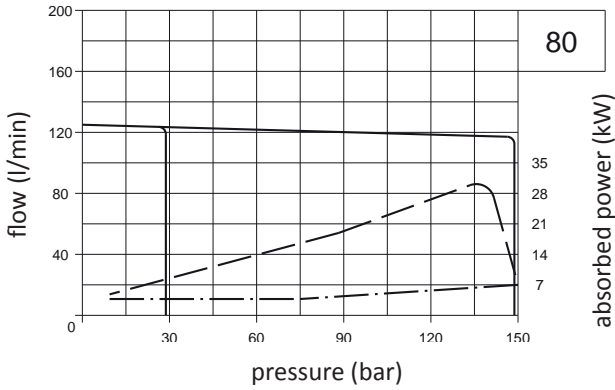

values established with zero flow setting

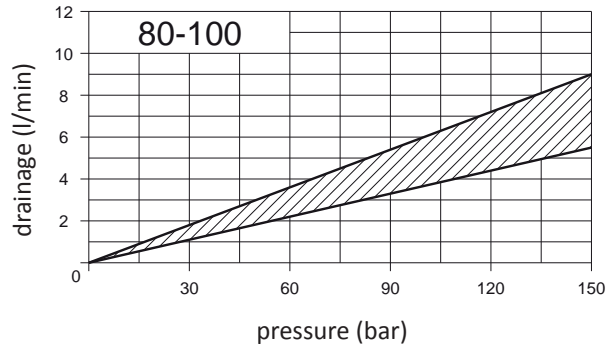

volumetric efficiency -zero flow setting curve

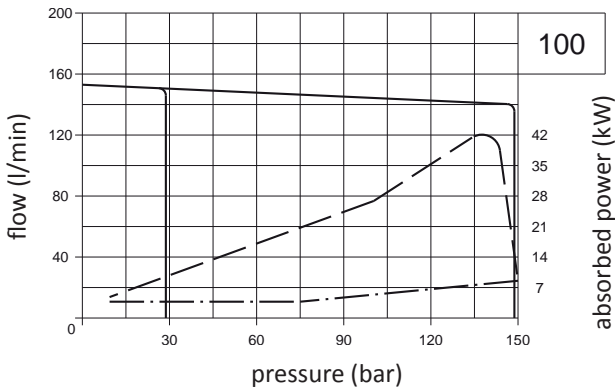

Noise level

Maximum noise level measured on Berarma test bench with sound-level meter placed 1 metre from the pump, with flexible coupling

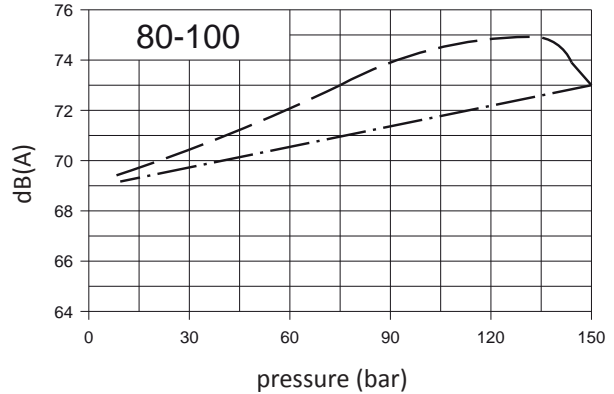

Power consumption with maximum flow

Power consumption with zero flow setting

Response time and pressure peak

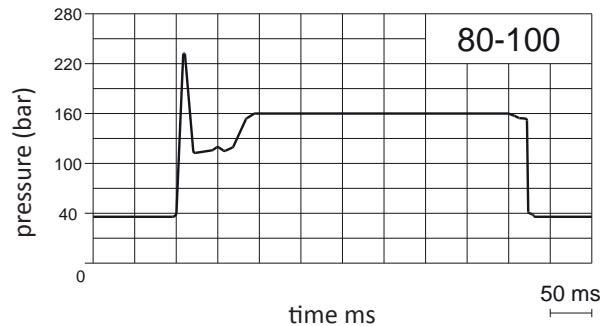

Pressure peaks are due to the test system. Pressure peaks exceeding 30% of the maximum operating pressure must be eliminated by adopting the appropriate measures.

OVERALL DIMENSIONS

02 PSP 80-100 (F)

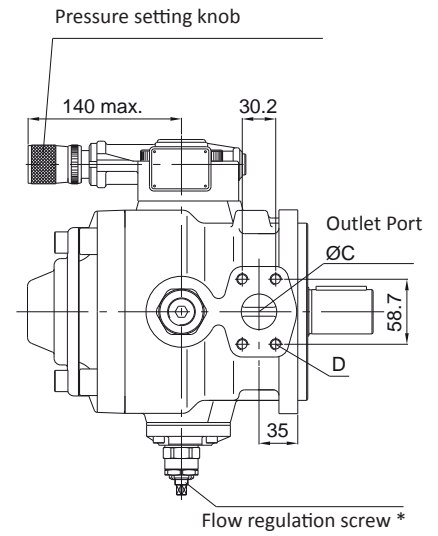
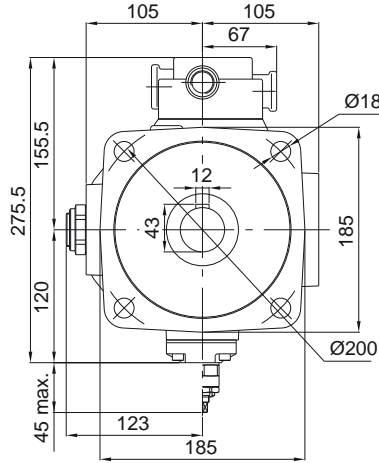
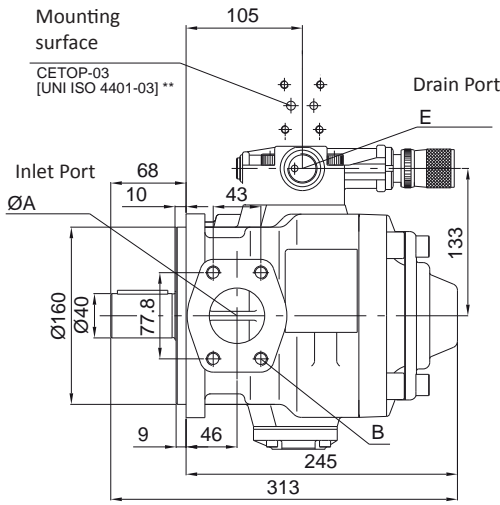

* - Supplied on request (see page 15)

** - Supplied on request (dimensions: see page 12)

Flange	ØA	B	ØC	D	E
F (ISO)	51	SAE (3000) 2" M12x45	32	SAE (3000) 1"1/4 M10x40	3/4" Gas (BSP)

ACCESSORIES

KEY-LOCK PRESSURE COMPENSATOR DEVICE

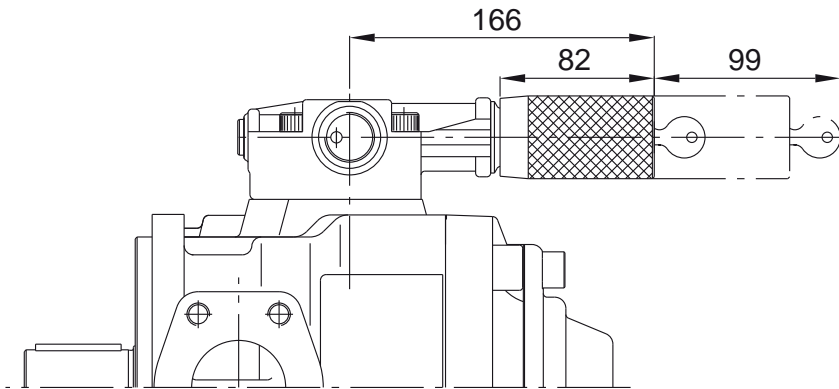

Note: In the case of combined pumps with Key-Lock pressure compensator, please contact Berarma Technical Service.

PRESSURE RELIEF VALVE FOR PSP PUMP (CODE 2010500600)

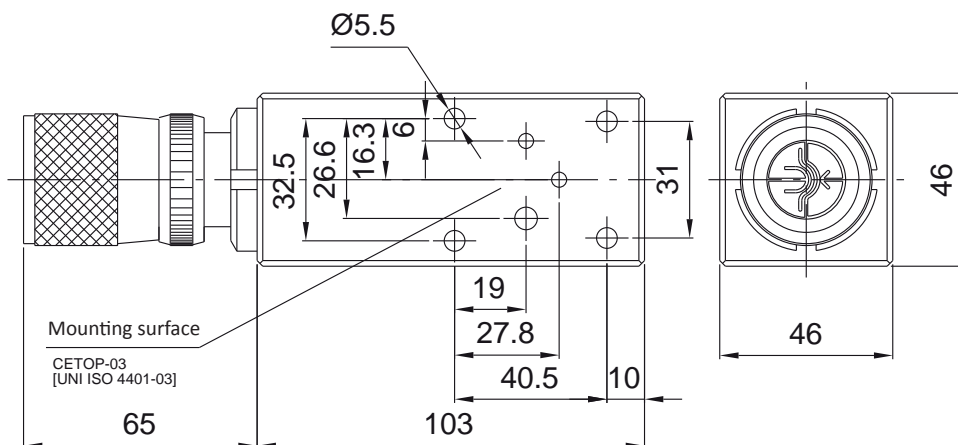

KEY-LOCK PRESSURE RELIEF VALVE FOR PSP PUMP (CODE 2010500700)

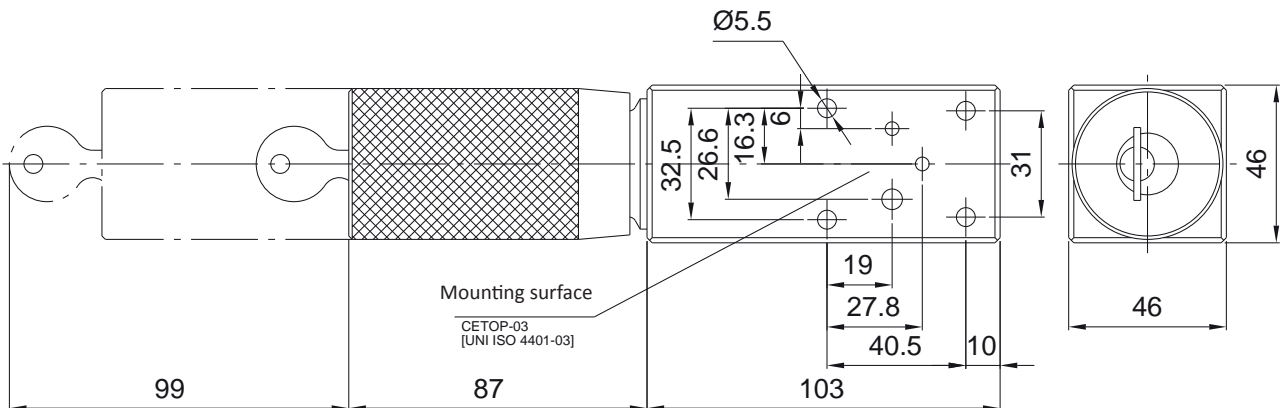

FLOW-RATE REGULATOR UNIT

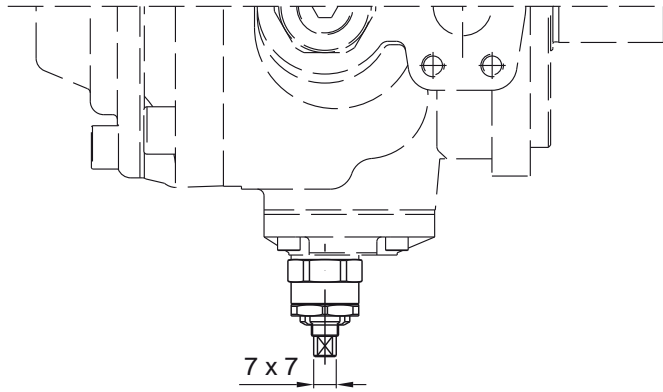

If the pump is supplied with flow-rate regulator unit "Q", set to less than 50% of the nominal flow, the pump can only start on condition that the system and pump are completely filled with fluid.

Pump type	02PSP 3-80	02PSP 3-100
Indicative data that can change from pump to pump		
MAX flow at 1450 r/min (l/min)	125	152
MIN flow at 1450 r/min (l/min)	39	66
Reduced flow by screw turn (l/min)	34.5	34.5

FLANGES SAE J518 (3000 SERIES) SUPPLIED WITH SCREWS AND O-RING

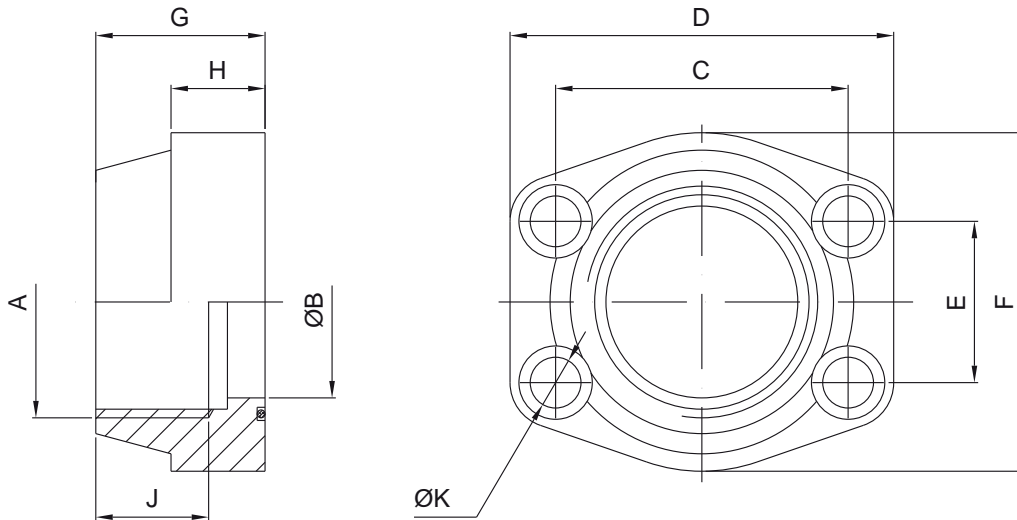

Pump type	Ordering code	Nominal size	A	ØB	C	D	E	F	G	H	J	ØK	Screws	O-Ring
02 PVS PSP 3	5540000104	1" 1/4	1" 1/4 Gas (BSP)	32	58.7	79	30.2	68	41	21	22	11.5	M10	OR 4150 NBR
	5540000108	2"	2" Gas (BSP)	51	77.8	102	42.9	90	45	25	30	13.5	M12	OR 4225 NBR

INSTRUCTIONS FOR INSTALLATION AND USE

- PSP pumps must be mounted with the shaft along a horizontal axis and with the compensator device facing upward (see figure).
 When the pump is installed above the tank oil level, pay attention to the inlet pressure (see page 6).
 Select the clear width of the pipes according to the pump inlet ports. The inlet pipes should be as short as possible, with a small number of bends and without internal section changes.
- All return and drain pipes must be positioned so that the oil cannot be sucked back directly by the pump (see figure).
 The oil tank must be suitably sized in order to exchange the thermal power generated by the various system components and to provide a low recycle rate.
 To ensure the maximum pump working life, the inlet oil temperature must never be above 50°C. In systems where the pump runs for a long time under zero flow setting conditions, the installation of a heat exchanger in the drain line is recommended.
 The pressure on the drain port must never exceed the specified value (page 6).
 The drain pipe must always be independent from the other return lines, connected directly to the tank, and extended sufficiently inside the tank so as to be below the minimum oil level to avoid generating foam. Moreover, the drain pipe must be free of restrictions and as far as possible from the inlet pipe.
- Motor-pump coupling must be made with a self-aligning flexible coupling with convex teeth and a polyamide cam. When assembling, maximum attention must be given to the distance between the half-couplings which must strictly fall within the values specified in the diagram below (detail "A").
 Other types of motor-pump couplings are not permitted.
 No induced RADIAL or AXIAL LOADS are allowed on the pump shaft.
- During initial installation, the pump must be run under maximum flow conditions (P connected to T), with the oil flowing directly into the tank, in order to induce air bleeding.
 For sizes 2 and 3 there is an air bleed on the compensator.
 This phase must run for several minutes. Pump priming (delivery of oil to the outlet) must occur within a few seconds, otherwise the pump must be turned off and the operation repeated. Subsequent start-ups under zero flow setting conditions are admissible only with pressure not exceeding 30 bar, and with the system and pump completely filled with oil.
 During the initial and subsequent starting operations, the difference between the oil temperature and the ambient temperature (body pump temperature) must not exceed 20°C.

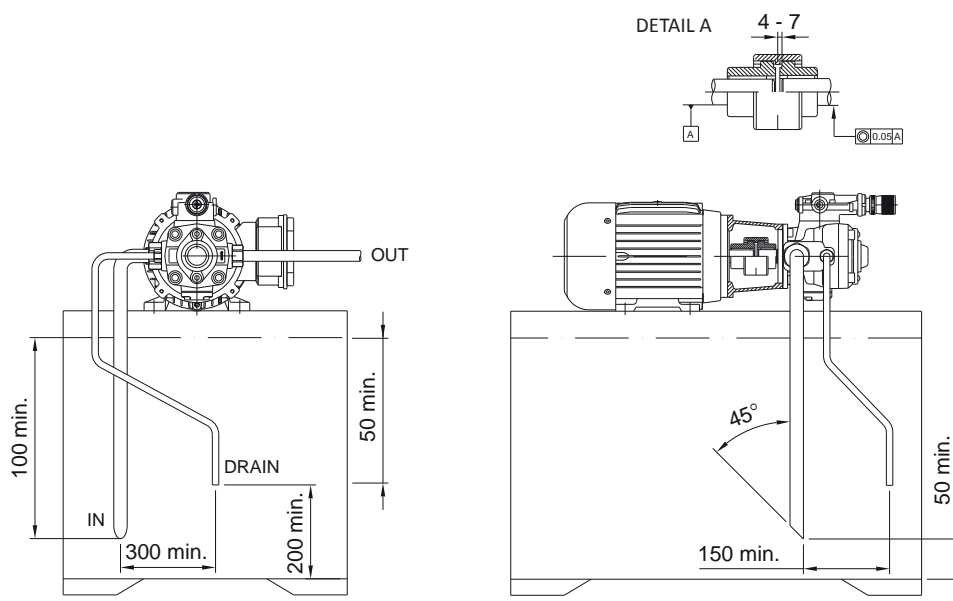

For further information, please consult the leaflet "Installation and start-up instructions for variable displacement vane combined pumps".

